

Answering Service  
Requests

---

**Safe Winter  
Operations**

---

Fire Protection:  
Engines and  
Auxiliary Power  
Units

---

787 Dreamliner:  
Updating Airplane  
Software  
Configurations

---

New Service  
Requests  
Application

# AERO



# AERO

03

**Answering Service Requests**  
A new online tool means less waiting, better tracking, and more streamlined communication with the Boeing team.

05

## Safe Winter Operations

Airlines need to be aware of recent developments in winter operations and review and update their cold weather operations procedures accordingly.

15

## Fire Protection: Engines and Auxiliary Power Units

Boeing incorporates extensive measures for fire protection, including fire detection and extinguishing systems, in engine pods and auxiliary power units.

21

## 787 Dreamliner: Updating Airplane Software Configurations

Airlines can change a number of 787 airplane software options without a service bulletin.

27

## New Service Requests Application

Boeing provides operators with a standard way to submit requests for in-service support.

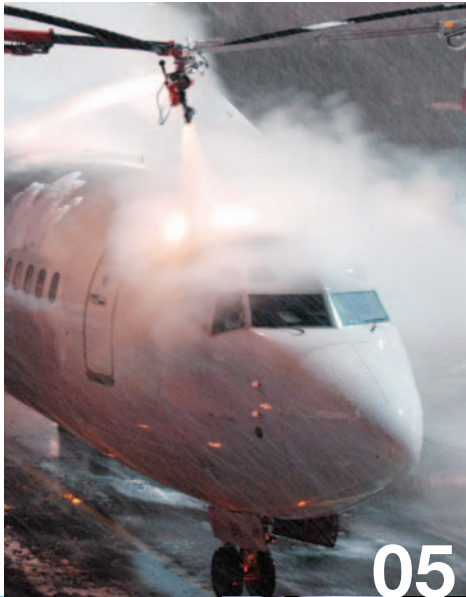

05



21



15

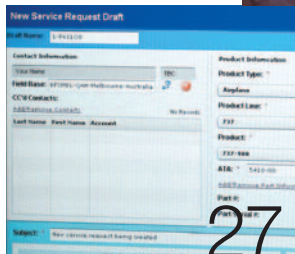

27

# AERO

**Publisher**

Shannon Frew

**Editorial director**

Jill Langer

**Editor-in-chief**

Jim Lombardo

**Design**

Methodologie

**Writer**

Jeff Fraga

**Distribution manager**

Nanci Moultrie

**Cover photography**

Jeff Corwin

**Printer**

ColorGraphics

**Web site design**

Methodologie

**Editorial Board**

Gary Bartz, Richard Breuhaus, Tom Dodt, Justin Hale, Darrell Hokuf, Al John, Doug Lane, Jill Langer, Russell Lee, Duke McMillin, David Presuhn, Wade Price, Bob Rakestraw, Frank Santoni, Jerome Schmelzer

**Technical Review Committee**

Gary Bartz, Richard Breuhaus, David Carbaugh, Tom Dodt, Justin Hale, Darrell Hokuf, Al John, Doug Lane, Jill Langer, Russell Lee, Duke McMillin, David Palmer, David Presuhn, Wade Price, Jerome Schmelzer, William Tsai

**AERO Online**

[www.boeing.com/commercial/aeromagazine](http://www.boeing.com/commercial/aeromagazine)

*AERO* magazine is published quarterly by Boeing Commercial Airplanes and is distributed at no cost to operators of Boeing commercial airplanes. *AERO* provides operators with supplemental technical information to promote continuous safety and efficiency in their daily fleet operations.

The Boeing Company supports operators during the life of each Boeing commercial airplane. Support includes stationing Field Service representatives in more than 60 countries, furnishing spare parts and engineering support, training flight crews and maintenance personnel, and providing operations and maintenance publications.

Boeing continually communicates with operators through such vehicles as technical meetings, service letters, and service bulletins. This assists operators in addressing regulatory requirements and Air Transport Association specifications.

Copyright © 2010 The Boeing Company

Information published in *AERO* magazine is intended to be accurate and authoritative. However, no material should be considered regulatory-approved unless specifically stated. Airline personnel are advised that their company's policy may differ from or conflict with information in this publication. Customer airlines may republish articles from *AERO* without permission if for distribution only within their own organizations. They thereby assume responsibility for the current accuracy of the republished material. All others must obtain written permission from Boeing before reprinting any *AERO* article.

Print copies of *AERO* are not available by subscription, but the publication may be viewed on the Web at [www.boeing.com/commercial/aeromagazine](http://www.boeing.com/commercial/aeromagazine).

Please send address changes to [me.boecom@boeing.com](mailto:me.boecom@boeing.com). Please send all other communications to *AERO* Magazine, Boeing Commercial Airplanes, P.O. Box 3707, MC 21-72, Seattle, Washington, 98124-2207, USA.  
E-mail: [WebMaster.BCA@boeing.com](mailto:WebMaster.BCA@boeing.com)

*AERO* is printed on Forest Stewardship Council Certified paper.





# Answering Your Service Requests Quickly and Thoroughly



One of the most important services that we provide you, our valued customers, is answering technical questions about your in-service fleet. We know that when you submit a service request to us, you want a reply that is timely and complete.

That's why we developed the online Service Requests Application available on the MyBoeingFleet.com Web portal. This electronic form lets you fill in all the relevant information for your service request and puts that request into an electronic repository for faster, more complete, and traceable action by Boeing.

With the Service Requests Application, you don't need to send multiple faxes and e-mails to Boeing individuals and

groups. You have one place for all information and correspondence regarding your service request.

Find out more about this new tool on page 27 of this issue of *AERO*. It will mean less waiting, better tracking, and more streamlined communication with the Boeing team.

Thank you.

**LOU MANCINI**

Senior Vice President,  
Boeing Commercial Aviation Services



Airlines need to be aware of recent developments in winter operations and regularly update their cold weather operations procedures.



# Safe Winter Operations

Airline engineering, maintenance, and flight personnel, as well as contracted airplane deicing service providers, need to be aware of the recent developments and recommendations for operating airplanes in winter weather conditions.

**By Haruhiko (Harley) Oda**, Flight Operations Engineer;

**Philip Adrian**, 737 Chief Technical Pilot;

**Michael Arriaga**, Service Engineer;

**Lynn Davies**, Aerodynamics Engineer;

**Joel Hille**, Service Engineer;

**Terry Sheehan**, 737 Technical Pilot; and

**E.T. (Tom) Suter**, Service Engineer

Safe winter operations require special procedures by airline maintenance, engineering, flight, and deicing personnel. These procedures include deicing, anti-icing, cold weather maintenance, and flight operations.

This article discusses recent developments for winter operations. Intended for both maintenance and flight crews, it provides operators with guidance for reviewing and updating cold weather operations procedures. This article also outlines general concepts and tips on safe winter operations.

## THE CLEAN-AIRPLANE CONCEPT

The “clean-airplane” concept is derived from U.S. Federal Aviation Administration (FAA) Federal Aviation Regulation (FAR) 121.629, which states, “No person may take off an aircraft when frost, ice or snow is adhering to the wings, control surfaces, propellers, engine inlets, or other critical surfaces of the aircraft or when the takeoff would not be in compliance with paragraph (c) of this section. Takeoffs with frost under the wing in the area of the fuel tanks may be authorized by the Administrator.”

The FAR also prohibits dispatch or takeoff any time conditions are such that

frost, ice, or snow may reasonably be expected to adhere to the airplane, unless the certificate holder has an approved ground deicing/anti-icing program in its operations specifications that includes holdover time (HOT) tables.

The European Aviation Safety Agency (EASA), Transport Canada Civil Aviation (TCCA), and other regulatory authorities have requirements similar to FAR 121.629.

The clean-airplane concept describes an airplane that is aerodynamically clean — that is, free of frozen contaminants. The clean-airplane concept is important because airplane takeoff performance is based upon clean surfaces until liftoff.



**Figure 1: Elevator control**

Maintenance and ground crews should establish an inspection and cleaning schedule for deicing/anti-icing fluid residue to help ensure that no flight control restrictions will occur.

An airplane is designed using the predictable effects of airflow over clean wings. Contaminants such as frost, ice, or snow adhering to the wings disturb this airflow, resulting in reduced lift, increased drag, increased stall speed, potentially severe roll problems due to uneven lift, and possible abnormal pitch characteristics.

#### CONSIDERATIONS FOR MAINTENANCE AND GROUND CREWS

Airplane operation in cold weather conditions can cause special problems because of the effects of frost, ice, snow, slush, and low temperature. The airplane maintenance manual (AMM) provides procedures for removal of contaminants from the airplane and the prevention of subsequent accumulation of frost, ice, snow, or slush. In addition, the operator must ensure that the maintenance procedures for winter operations are appropriate for the weather conditions. (See “The basics of deicing and anti-icing” on page 9 and “General precautions during winter operations” on page 11.)

Boeing recommends that maintenance and ground crew personnel and contracted airplane deicing service providers acquaint themselves with these recent developments in the area of airplane deicing and anti-icing:

When thickened airplane deicing/anti-icing fluids (i.e., SAE International Types II, III, and IV fluids) dry, they may leave a very fine, powdery residue in critical areas in wings and stabilizers. This residue can rehydrate and expand into gel-like materials that can freeze during flight and cause restrictions in the flight control systems (see fig. 1). (For more information, see *AERO* first-quarter 2007.) As a result, operators should:

- Be aware of how frequently airplanes are being deiced/anti-iced.
- Be aware of whether a one- or two-step application process is being employed. While recognizing that it is not possible at some locations, Boeing recommends using a two-step process, preferably with Type I fluid and/or hot water as the first step. The application of hot water or heated Type I fluid as the first step of a two-step process has been shown to minimize the formation of residue gels.
- Ensure that proper procedures, including storage, handling, and application of fluids, are being followed by airline personnel or contracted deicing service providers.
- Establish an inspection and cleaning schedule for thickened fluid residue to help ensure that no flight control restrictions will occur. Examine areas such as wing rear spar, wing leading edge devices, horizontal stabilizer rear spar, vertical stabilizer, auxiliary power unit bay, control tabs and linkages

(when applicable), and the bilge area of the tail cone. Visually inspect for dry or rehydrated residues in these areas. This inspection and cleaning should be performed in accordance with the recommendations found in the AMM for the specific airplane model involved.

- Apply lubricants and corrosion inhibitors as necessary to the areas where residue cleaning occurs.

Airplane deicing/anti-icing fluids and many runway deicing fluids are not compatible — interaction between the two may contribute to the formation of gel residues. When these fluids combine, the salts in some runway fluids enhance the separation of the polymers contained in thickened airplane fluids, leading to a more rapid formation of gel residues.

When runway deicing fluid contaminates thickened airplane anti-icing fluid, there can be significant degradation of the fluid’s performance. HOT values can be reduced and adherence or unacceptable flow-off may result. Runway deicing fluid can get onto the wings and tails by various means, such as spray from the nose gear, spray kicked up by the engine exhaust of other airplanes, or from activation of the engine thrust reversers. Runway deicing fluids are hygroscopic fluids, so they don’t dry out very quickly, causing them to leave a thin wet layer on the wing that can be difficult to see. This implies that the use of hot





**Figure 2: Damage to carbon brake disks caused by runway deicers**

The damaged stator disk drive lugs on this carbon heat-sink demonstrate the type of damage alkali metal-based runway deicers can cause to carbon brake disks.

- Stator Disk Drive Lugs
- Stator Disk Drive Lugs Missing (oxidized)

water or Type I fluid to clean the wing prior to the application of thickened anti-icing fluid (i.e., Type II, III, or IV) is even more important than previously thought. On September 14, 2010, EASA issued Safety Information Bulletin 2010-26 on this subject, recommending the use of the two-step application process.

**Catalytic oxidation of carbon brakes may result from exposure of the brakes to alkali metal (i.e., organic salt)-based runway deicers.** This may cause severe damage to the brakes and drastically shorten their service life. These runway deicers have also caused corrosion of electrical connectors and hydraulic system components.

In the 1990s, runway deicing materials containing potassium and sodium acetate were introduced (potassium and sodium formate were introduced later) as an alternative to urea and glycol runway deicers. Urea and glycol runway deicers contribute to an increase in the biological and chemical oxygen demand of water systems surrounding airports and are more toxic to aquatic life than the alkali metal-based runway deicers.

Following the introduction of the new runway deicers, some operators reported that their airplanes equipped with carbon brakes began experiencing catalytic oxidation of the carbon brake heat-sink disks (see fig. 2). In order to help operators of airplanes equipped with carbon brakes

comply with FAA Special Airworthiness Information Bulletin NM-08-27 and EASA Safety Information Notice 2008-19R1, the main gear wheel removal/installation sections of applicable AMMs have been revised to recommend inspection of the carbon brake assembly for signs of catalytic oxidation damage whenever a wheel and tire assembly is removed.

Boeing has released several service letters regarding the corrosion caused by alkali metal-based runway deicers on various airplane parts, including hydraulic tubes and cadmium-plated electrical connectors.

#### CONSIDERATIONS FOR FLIGHT CREWS

Winter or cold weather operations are generally associated with a combination of low temperatures and frost, ice, slush, or snow on the airplane, ramps, taxiways, and runways. The airplane flight manual (AFM) defines icing conditions as when the outside air temperature (OAT) on the ground or total air temperature (TAT) in flight is 50 degrees F (10 degrees C) or less and any of the following exist:

- Visible moisture (e.g., clouds, fog with visibility of one statute mile [1,600 meters] or less, rain, snow, sleet, or ice crystals).
- Ice, snow, slush, or standing water on the ramps, taxiways, or runways.

On runways contaminated by slush, snow, standing water, or ice, the use of fixed derate reduced thrust is permitted, provided that airplane-takeoff-performance planning accounts for the runway surface condition. Use of the assumed temperature reduced thrust method, alone or in combination with a fixed derate, is not permitted on contaminated runways. Boeing does not recommend takeoffs when slush, wet snow, or standing water depth is more than 0.5 inch (13 millimeters) or dry snow depth is more than 4 inches (102 millimeters). (See “General precautions during winter operations” on page 11.)

Boeing recommends that flight crews make themselves aware of the following recent developments in the area of winter operations:

**Starting with the 2010 winter season, HOT guidelines for Type I fluids include a new set of times to be used when the fluids have been applied to composite surfaces.**

Testing performed during the last three winter seasons has shown that HOT values for Type I fluids on composite surfaces are significantly shorter (on the order of 30 percent) than for aluminum surfaces. Although this topic has been discussed in the FAA Notice of its “FAA-Approved Deicing Program Updates” for the last two winter seasons, this year both the FAA and TCCA are publishing separate HOT guidelines for composite surfaces. In addition to

The use of hot water or Type I fluid to clean the wing prior to the application of thickened anti-icing fluid (i.e., Type II, III, or IV) is even more important than previously thought.

extensive use of composites on newer models, many older models also have numerous composite surfaces (e.g., spoilers, ailerons, flaps, slats, etc.).

**During taxi-out, avoid using reverse thrust on snow- or slush-covered runways, taxiways, or ramps unless absolutely necessary.** Using reverse thrust on snow- or slush-covered ground can cause slush, water, and runway deicers to become airborne and adhere to wing surfaces.

#### AIRPLANE PERFORMANCE

Boeing currently provides two different landing-distance data sets to operators: dispatch data and in-flight operational data.

**Dispatch landing data** is used during flight planning to determine the maximum landing weight at which the airplane can land within the available landing distance at the destination or alternate airport. This data, referred to as certified data in the AFM, is based on standard-day temperature and accounts for airport pressure altitude and runway wind. However, it does not account for the effect of thrust reversers or runway slopes. Non-dry runway conditions are accounted for by factoring the dry runway dispatch landing-distance data.

**In-flight operational data** is published as advisory normal-configuration landing distance data in the performance in-flight section of a quick reference handbook (QRH). The data is provided as unfactored data for operators who use FAA requirements. The advisory data in the QRH for operators who use Joint Aviation Authorities or EASA requirements includes a 1.15 factor for non-dry runway conditions. The advisory data provided by Boeing is based on the use of reverse thrust and a 1,000-foot (305-meter) flare distance.

The FAA has chartered an aviation rulemaking committee (ARC) on takeoff and landing performance assessment (TALPA) to ensure that industry practices have adequate guidance and regulation for operation on non-dry, non-wet runways (i.e., contaminated runways). Based on the recommendations made by the ARC, the advisory normal-configuration landing-distance data for the 747-8 and 787 will include the following:

- Braking action and runway surface condition descriptions.
- 7-second air (flare) distance.
- A 1.15 factor for operators that use FAA requirements.

The 787 and 747-8 QRH advisory data will be based on the TALPA ARC recommendations. Changes to the QRH advisory data for other models, such as the 777 and the Next-Generation 737, will await final rulemaking. However, Boeing can provide guidance on how existing QRH normal-configuration landing data can be adjusted to meet the intention of the TALPA ARC recommendations.

#### SUMMARY

Airlines need to be aware of recent developments in winter operations and review and update their cold weather operations procedures accordingly.

For more information, please contact Harley Oda at [haruhiko.oda@boeing.com](mailto:haruhiko.oda@boeing.com). 

# The basics of deicing and anti-icing

**Deicing** removes accumulated frost, ice, or snow from an airplane, typically through the application of hot water or a hot mixture of water and deicing fluid. Although there are other approved methods for deicing—such as infrared heat or hot air—the primary method worldwide is the use of fluids.

**Anti-icing** prevents the adherence of frost, ice, or snow to airplane surfaces for a certain period of time (i.e., the HOT values). While the same fluids used for deicing are also used for anti-icing, SAE Types II, III, and IV fluids are more typically used for anti-icing because they are thickened to stay on the airplane and thus provide longer HOT protection. They are most effective when applied unheated and undiluted to a clean airplane surface.

Whether used for deicing or anti-icing, the fluids must be transported, stored, and handled properly to be effective. Operators must ensure that the fluid manufacturer's guidelines are followed for the entire deicing/anti-icing process.

## DEICING AND ANTI-ICING FLUIDS

The SAE standards define four types of deicing and anti-icing fluids. These fluids

are acceptable for use on all Boeing airplanes (see fig. A):

- Type I fluids are unthickened and typically have a minimum of 80 percent glycol and a relatively low viscosity, except at very cold temperatures. These fluids provide some anti-icing protection, primarily due to the heat required for deicing, but have a relatively short HOT. Standards for Type I fluids are published in SAE Aerospace Material Specification (AMS) 1424.
- Type II, III, and IV fluids typically contain a minimum of 50 percent glycol in addition to polymer thickening agents. The thickening agents delay the flow-off of the fluids from the airplane surfaces. As a result, Type II, III, and IV fluids provide longer HOT values than Type I fluids. The flow-off characteristics of Type III fluids make them more suitable for commuter airplanes with relatively low takeoff rotation speeds. Type IV fluids provide longer HOTs than Type II fluids. Standards for Type II, III, and IV fluids are published in SAE AMS 1428.

In accordance with AMS 1424 and 1428, all fluids must pass an Aerodynamic Acceptance Test to be considered qualified

fluids that can be used on airplanes. All fluids must be requalified every two years.

Military (MIL) specifications for deicing/anti-icing fluids (such as MIL-A-8243D Type 1 and 2) are no longer kept up to date. Boeing recommends updating service documents to reference SAE standards if they currently reference MIL specifications.

## HOLDOVER TIME

HOT is the length of time that anti-icing fluid will prevent ice and snow from adhering to and frost from forming on the treated surfaces of an airplane. These times are only guidelines; a number of variables can reduce protection time, including:

- The heavier the precipitation, the shorter the HOT.
- High winds or jet blast that cause the fluid to flow off, decreasing the protection afforded by the fluid layer.
- Wet snow, which causes fluids to dilute and fail more quickly than dry snow.
- An airplane skin temperature lower than outside air temperature.
- Direct sunlight followed by precipitation.
- The use of incorrect equipment to apply fluids.



## Figure A: Identifying deicing and anti-icing fluids by color

The four types of deicing/anti-icing fluids can be readily identified by their color.

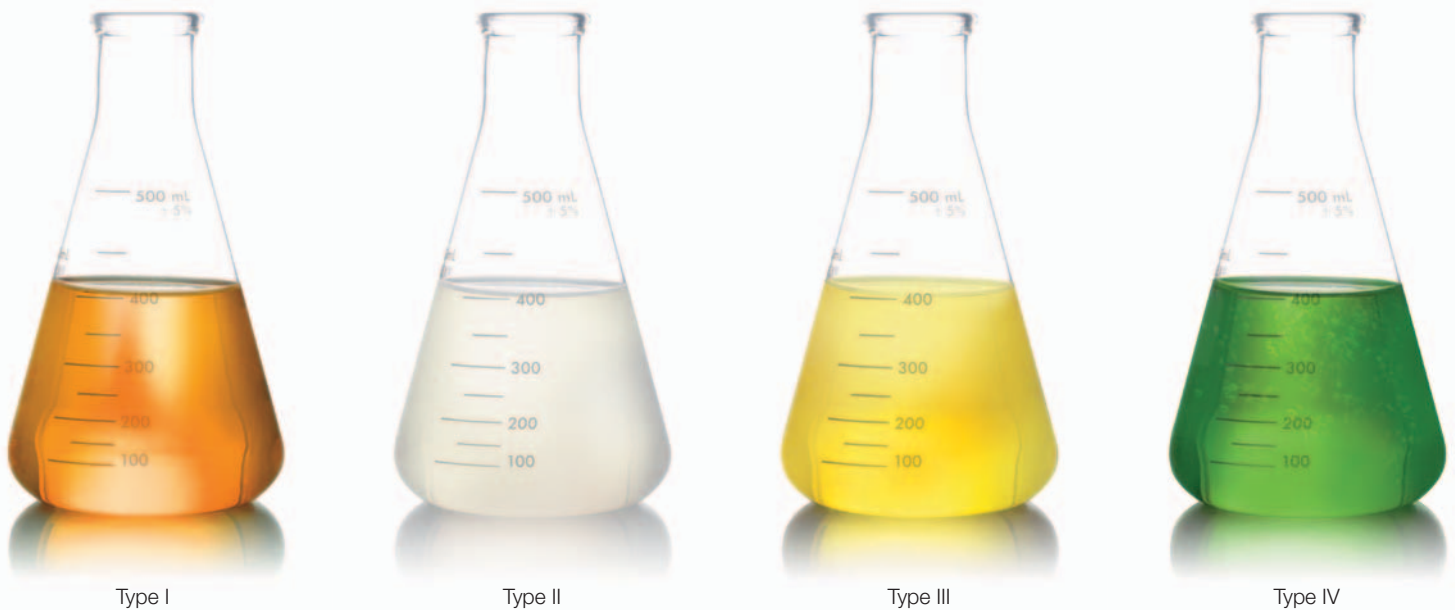

For each winter season, the FAA publishes an annual Approved Deicing Program Update in an 8900.xx Notice (where the “xx” changes each year) that includes HOT guidelines for all commercially available deicing/anti-icing fluids that are currently qualified.

Similarly, TCCA annually publishes tables of HOT values in its Transport Canada Holdover Time Guidelines.

### APPLYING DEICING/ANTI-ICING FLUIDS

There are two methods for applying deicing and anti-icing fluids.

**One-step process:** This process accomplishes both the deicing and anti-icing steps with a single fluid application. Typically a heated mixture of thickened fluid and water is applied.

**Two-step process:** This process involves deicing with heated Type I fluid, a heated

mixture of Type I fluid and water, or a heated mixture of water and thickened (Type II, III, or IV) fluid, followed by a separate application of thickened fluid for anti-icing protection. Experience and testing have shown that deicing with heated Type I fluid or a heated mixture of water and Type I fluid will help remove residue from previous anti-icing fluid treatments. Deicing with heated thickened fluid may contribute to residue formation.

# General precautions during winter operations

## For maintenance crews

These are general guidelines; refer to the AMM for definitive information.

- Ice that has accumulated on the fan blades while the airplane has been on the ground for a prolonged stop is called “ground-accumulated ice” and must be removed before engine start.
- Ice that has accumulated on the fan blades while the engine is at idle speed is called “operational ice” and is allowed to remain on the fan blades before taxi because the ice will be removed by engine run-ups prior to takeoff.
- The right and left sides of the wing and horizontal stabilizer (including the elevator) must receive the same fluid treatment, and both sides of the vertical stabilizer must receive the same fluid treatment.
- Treat the wings and tails from leading edge to trailing edge and outboard to inboard.
- Treat the fuselage from the nose and work aft. Spray at the top centerline and work outboard.
- Do not point a solid flow of fluid directly at the surfaces, gaps in airframe structure, or antennas. Instead, apply the fluid at a low angle to prevent damage, while pointing aft for proper drainage.
- Make sure that all of the ice is removed during deicing. There may be clear ice below a layer of snow or slush that is not easy to see. As a consequence, it may be necessary to feel the surface to adequately inspect for ice.
- Do not spray deicing/anti-icing fluids directly into auxiliary power unit (APU) or engine inlets, exhausts, static ports, pitot-static probes, pitot probes, or TAT probes.
- Do not spray hot deicing/anti-icing fluid or hot water directly on windows as it may cause damage.
- Ensure that ice or snow is not forced into areas around flight controls during deicing.
- Remove all ice and snow from passenger doors and girt bar areas before closing.
- Cargo doors should be opened only when necessary. Remove the ice and snow from the cargo containers before putting them on the airplane.
- If SAE Type II, III, or IV fluids are used, remove all of the deicing/anti-icing fluid from the cockpit windows prior to departure to ensure visibility.
- Deicing/anti-icing fluid storage tanks must be constructed of a compatible material. For thickened fluids, the tanks must be of a material that is not susceptible to corrosion (e.g., stainless steel or fiberglass). This is particularly important for thickened fluids because their viscosity can be permanently decreased if they are contaminated or exposed to excessive heat or mechanical shear during handling and application.
- When there is ice, slush, snow, or standing water on the runways or taxiways during taxi-in, examine the airplane when it gets to the ramp. Look for any damage to the airplane surfaces and for contamination that may have collected on the airplane. Carefully remove the contamination.
- Proper maintenance procedures for landing gear during cold weather operation as defined in the AMM can help reduce degradation of the structural joints and ensure optimal shock strut performance.
- Operating during cold weather can adversely affect the ability to properly lubricate the landing gear joints. Where possible, perform scheduled lubrication at maintenance bases where the temperature is above freezing. A heated hangar is the next most effective means of ensuring proper lubrication. If lubrication must be accomplished outside a heated hangar in temperature below freezing, the landing gear structure itself should be heated by blowing hot air directly onto the structure or into an enclosure around the structure.
- The temperature surrounding the airplane has a direct effect on both the volume of the gas and the viscosity of the oil in the shock strut. Boeing multi-model service letters provide procedures to ensure optimum strut performance if an airplane operates between two different regions with significantly different temperatures.
- Do not point a spray of deicing/anti-icing fluid directly onto wheels or brake assemblies.
- Remove contamination (e.g., frost, ice, slush, or snow) from the area where the main and nose gear tires will be positioned when the airplane is parked at the gate. If tires are frozen to the ramp, the airplane should not be moved until they are free.

## For flight crews

These are general guidelines; refer to the Boeing flight crew operations manuals (FCOM) for definitive information.

### PRIOR TO TAXI

- Carefully inspect areas where surface snow, ice, or frost could change or affect normal system operations. Perform a normal exterior inspection with increased emphasis on checking surfaces, pitot probes and static ports, air-conditioning inlets and exits, engine inlets, fuel-tank vents, landing-gear doors, landing-gear truck beam, brake assemblies, and APU air inlets. Takeoff with a light coating of frost (up to 1/8 inch [3 millimeters] thick) on *lower* wing surfaces caused by cold fuel is allowable. However, all leading-edge devices, all control surfaces, the horizontal tail, vertical tail, and *upper* surface of the wing must be free of snow, ice, and frost.
- Perform the normal engine start procedures, but note that oil pressure may be slow to rise. Displays may require additional warm-up time before engine indications accurately show changing values. Displays may appear less bright than normal.
- Engine anti-ice must be selected ON immediately after both engines are started, and it must remain on during all ground operations when icing conditions exist or are anticipated. Do not rely on airframe visual icing cues before activating engine anti-ice. Use the temperature and visible moisture criteria.

- Operate the APU only when necessary during deicing/anti-icing treatment.
- Do not operate the wing anti-ice system on the ground when thickened fluids (e.g., SAE Type II, III, or IV) have been applied. Do not use the wing anti-ice system as an alternative method of ground deicing/anti-icing.
- If the taxi route is through ice, snow, slush, or standing water, or if precipitation is falling with temperatures below freezing, taxi out with the flaps up. Taxiing with the flaps extended subjects flaps and flap devices to contamination.
- Check the flight controls and flaps to ensure freedom of movement.
- If there are any questions as to whether the airplane has frozen contamination, request deicing or proceed to a deicing facility. Never assume that snow will blow off; there could be a layer of ice under it. In rainy conditions with OAT near freezing, do not assume that raindrops on surfaces have remained liquid and will flow off; they could have frozen onto the surface. A similar issue can occur due to cold-soaked fuel in the wing tanks.
- Ice that has accumulated on the fan blades while the airplane has been on the ground for a prolonged stop is called “ground-accumulated ice” and must be removed before engine start.
- Ice that has accumulated on the fan blades while the engine is at idle speed is called “operational ice” and is allowed to remain on the fan blades before taxi because the ice will be removed by engine run-ups prior to takeoff.

### DURING TAXI

This guidance is applicable for normal operations using all engines during taxi.

- Allowing greater than normal distances between airplanes while taxiing will aid in stopping and turning in slippery conditions. This will also reduce the potential for snow and slush being blown and adhering onto the airplane or engine inlets.
- Taxi at a reduced speed. Taxiing on slippery taxiways or runways at excessive speed or with strong crosswinds may cause the airplane to skid. Use smaller nose-wheel steering and rudder inputs. Limit thrust to the minimum required.
- Use of differential engine thrust assists in maintaining airplane momentum through a turn. When nearing turn completion, placing both engines at idle thrust reduces the potential for nose-wheel skidding. Differential braking may be more effective than nose-wheel steering on slippery or contaminated surfaces.
- Nose-wheel steering should be exercised in both directions during taxi. This circulates warm hydraulic fluid through the steering cylinders and minimizes the steering lag caused by low temperatures.
- During prolonged ground operations, periodic engine run-ups should be performed per the Boeing FCOM to shed the accreted ice.



## BEFORE/DURING TAKEOFF

- Do the normal Before Takeoff Procedure. Extend the flaps to the takeoff setting at this time if they have not been extended because of slush, standing water, icing conditions, or because of deicing/anti-icing.
- Verify that airplane surfaces are free of ice, snow, and frost before moving into position for takeoff.
- In icing conditions, refer to the Boeing FCOM for guidance regarding static engine run-up before takeoff.
- Before brake release, check for stable engine operation. After setting takeoff engine pressure ratio (EPR), or N1, check that engine indications are normal, in agreement, and in the expected range. Check that other flight deck indications are also normal.
- Rotate smoothly and normally at  $V_R$ . Do not rotate aggressively when operating with deicing/anti-icing fluid.
- Retract flaps at the normal flap retraction altitude and on the normal speed schedule.
- A larger temperature difference from International Standard Atmosphere (ISA) results in larger altimeter errors. When the temperature is colder than ISA, true altitude is lower than indicated altitude. Consider applying the Boeing FCOM Cold Temperature Altitude Corrections, especially where high terrain and/or obstacles exist near airports in combination with very cold temperatures (-22 degrees F/-30 degrees C or colder).

Operator coordination with local and en-route air traffic control facilities is recommended.

## DESCENT

- Unless the airplane has fully automatic activation of ice protection systems, anticipate the need for activating the engine and/or wing anti-ice systems at all times, especially during a descent through instrument meteorological conditions or through precipitation.
- When anti-ice systems are used during descent, be sure to observe Boeing FCOM minimum EPR/N1 limits (if applicable).

## LANDING

- The flight crew must be aware of the condition of the runway with respect to ice, snow, slush, or other contamination.
- Follow the normal procedures for approach and landing. Use the normal reference speeds unless otherwise directed by the Boeing FCOM.
- Arm the autobrake and autospoiler systems, if available, before landing.
- The airplane should be firmly flown onto the runway at the aiming point.
- Immediately after main-gear contact with the runway, deploy the speed brakes if not already deployed by the automatic system.
- Without delay, lower the nose-wheel to the runway to gain nose-wheel directional

control. Do not hold the nose gear off the runway when operating on slippery or icy runways.

- Use of autobrakes is recommended. They will allow the pilot to better concentrate on directional control of the airplane. If manual braking is used, apply moderate to firm steady pedal pressure symmetrically until a safe stop is assured.
- Let the anti-skid system do its work. Do not pump the brake pedals.
- Do not use asymmetric reverse thrust on an icy or slippery runway unless necessary to arrest a skid.
- When using reverse thrust, be prepared for a possible downwind drift on a slippery runway with a crosswind.
- During winter operations, it is even more important than usual that the flight crew not attempt to turn off the runway until the airplane has slowed to taxi speed.
- Taxi at a reduced speed. Taxiing on slippery taxiways or runways at excessive speed or with strong crosswinds may cause the airplane to skid.
- The Cold Weather Operations Supplementary Procedure in the Boeing FCOM specifies how far the flaps may be retracted after landing in conditions where ice, snow, or slush may have contaminated the flap areas. If the flap areas are found to be contaminated, flaps should not be retracted until maintenance has removed the contaminants.
- Use the engine anti-ice system during all ground operations when icing conditions exist or are anticipated.

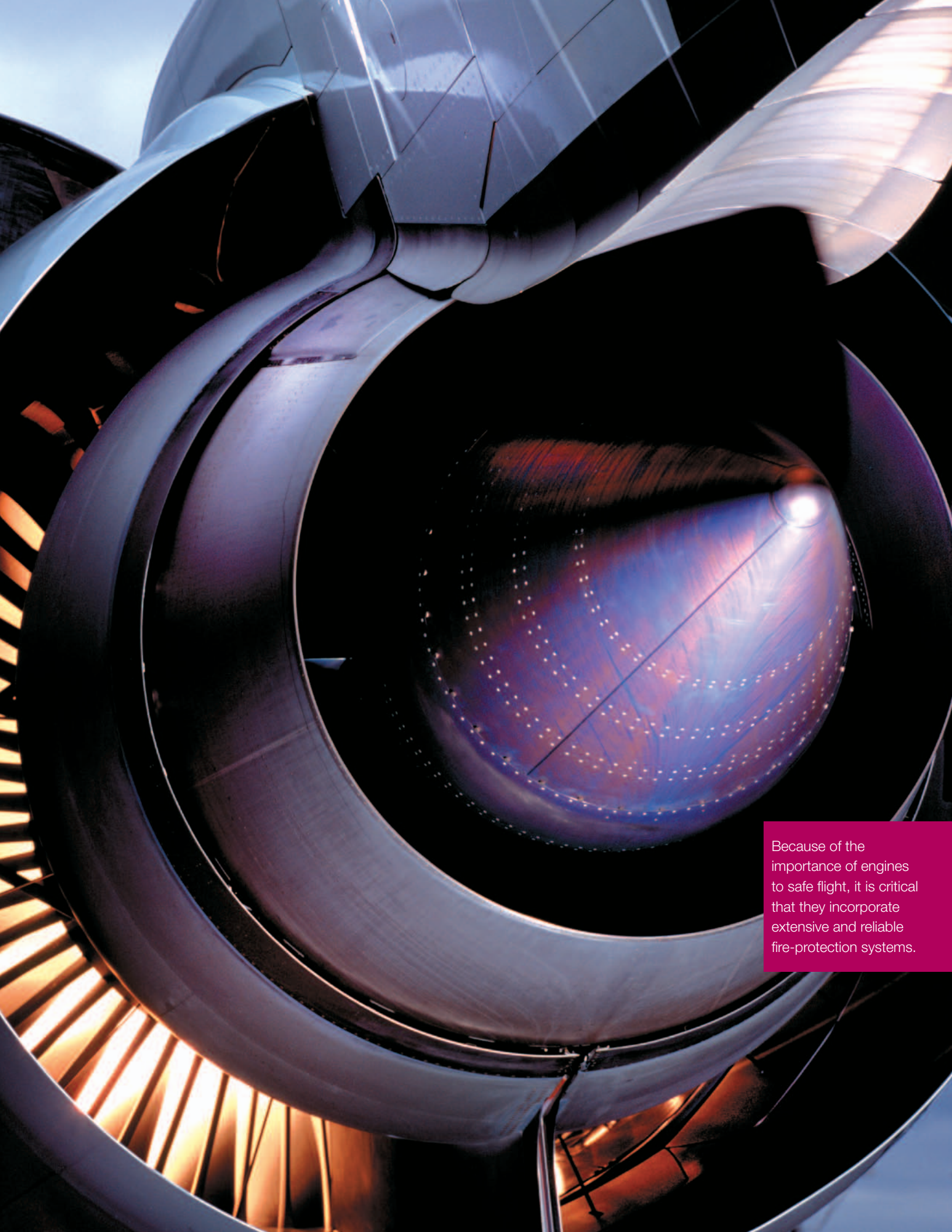

Because of the importance of engines to safe flight, it is critical that they incorporate extensive and reliable fire-protection systems.

# Fire Protection: Engines and Auxiliary Power Units

The engines and auxiliary power units (APUs) on Boeing airplanes incorporate extensive measures for fire protection, including fire detection and extinguishing systems.

**By Sham Hariram**, Technical Fellow, Boeing Propulsion Engineering;  
**Paul Philipp**, Senior Propulsion Engineer, Boeing Propulsion Engineering; and  
**Dave Dummeyer**, Associate Technical Fellow, Boeing Propulsion Engineering

*This article is the first in a series exploring the implementation of fire protection on transport category airplanes.*

Fire protection is given one of the highest considerations at Boeing in airplane design, testing, and certification.

In designing an airplane's fire protection systems, Boeing uses the principles of separation, isolation, and control. These principles involve separating the three essentials for creating a fire (i.e., fuel, ignition source, and oxygen), isolating potential fires from spreading to other parts of the airplane, and controlling a fire should one occur.

To effect this separation, isolation, and control, Boeing uses both passive and active systems. Passive systems include the use of noncombustible or self-extinguishing materials; separation by routing, compartmentation, isolation, ventilation, and drainage; and bonding and grounding. Active systems include fire and overheat detection systems, fire-extinguishing systems, temperature sensing, air and fuel shut-off means, and automatic shutdown of nonflight critical systems. Fire protection systems on Boeing airplanes meet all aviation regulatory requirements as well as internal Boeing design requirements.

Because of the importance of engines to safe flight, it is critical that they incor-

porate extensive and reliable fire-protection systems. The APU utilizes similar systems. This article describes how Boeing provides fire protection for the engine pods, also termed "engines," and for APUs. An engine pod consists of the engine, the inlet, the nacelle, the thrust reverser, the exhaust section, and the strut or pylon.

## PASSIVE FIRE-PROTECTION SYSTEMS

**Engine zones.** The engines and strut or pylon structures on Boeing airplanes form compartments, each of which is isolated by basic structure and ancillary surfaces. Each engine nacelle or strut compartment



## Figure 1: Compartmentation in a typical engine pod

Engine pods incorporate zones designed to minimize the probability of a fire and to isolate a fire, should one occur.

### Side View

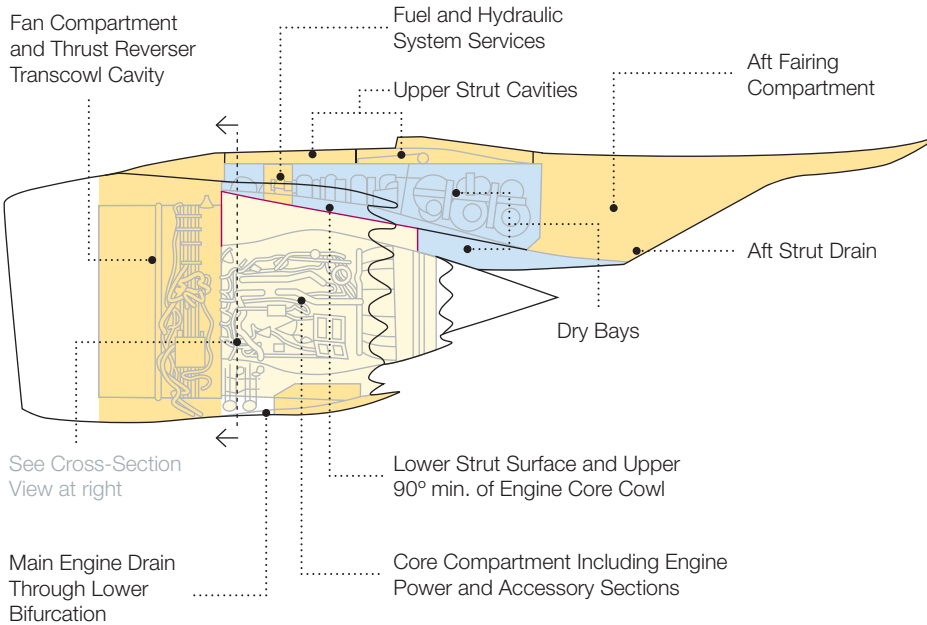

### Cross Section

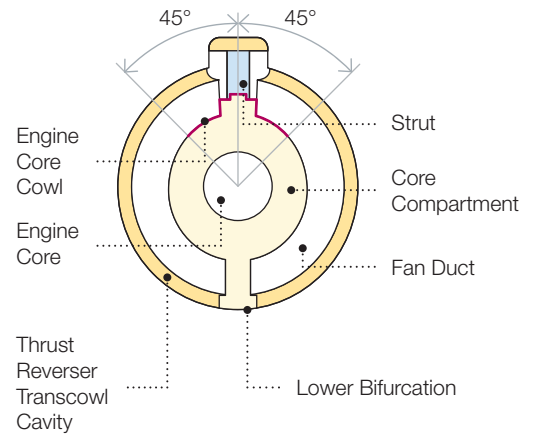

● Flammable Fluid Leakage Zone   
 ● Fire Zone   
 ● Dry Bay Zone   
 — Firewall

## Figure 2: A typical APU compartment

The APU compartment firewall isolates the APU from the rest of the airplane.

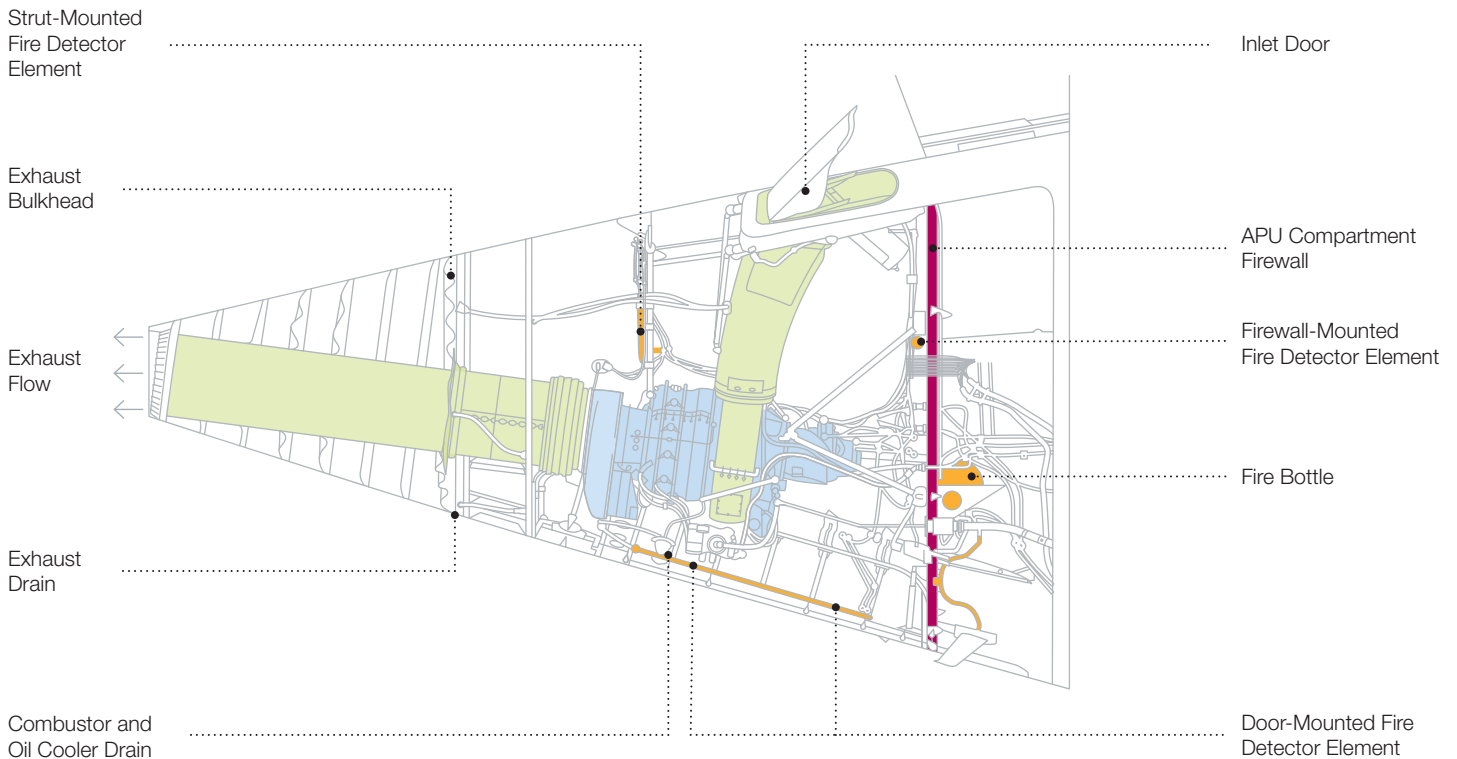

● Exhaust Flow   
 ● Fire Bottle and Fire Detector Elements   
 ● APU   
 ● Firewall

### Figure 3: A typical strut or pylon

Strut structures incorporate numerous firewalls of various materials to isolate strut and wing areas adjacent to engine fire zones.

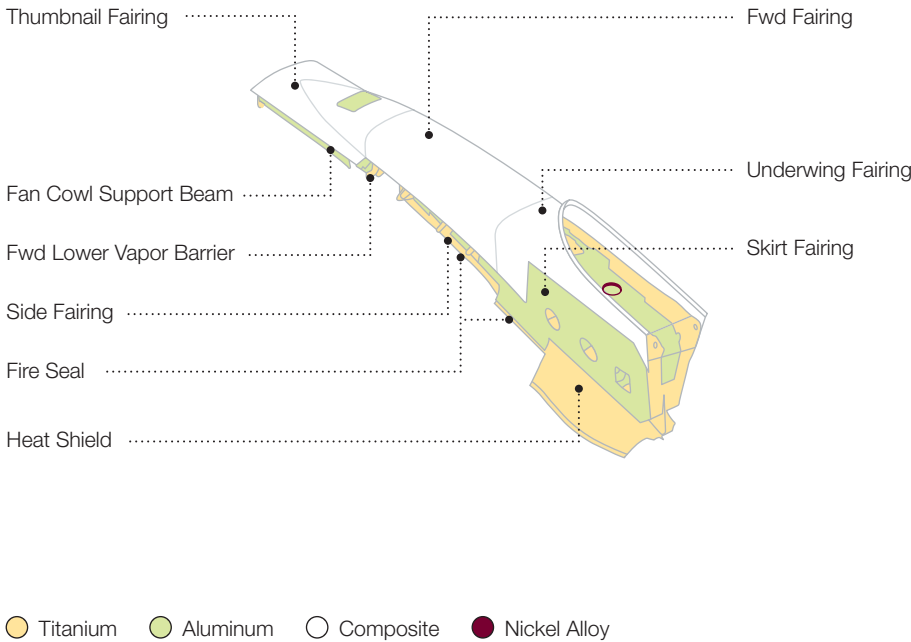

### Figure 4: Typical engine fire and overheat detector locations

Nacelle compartments contain multiple fire or overheat detector elements.

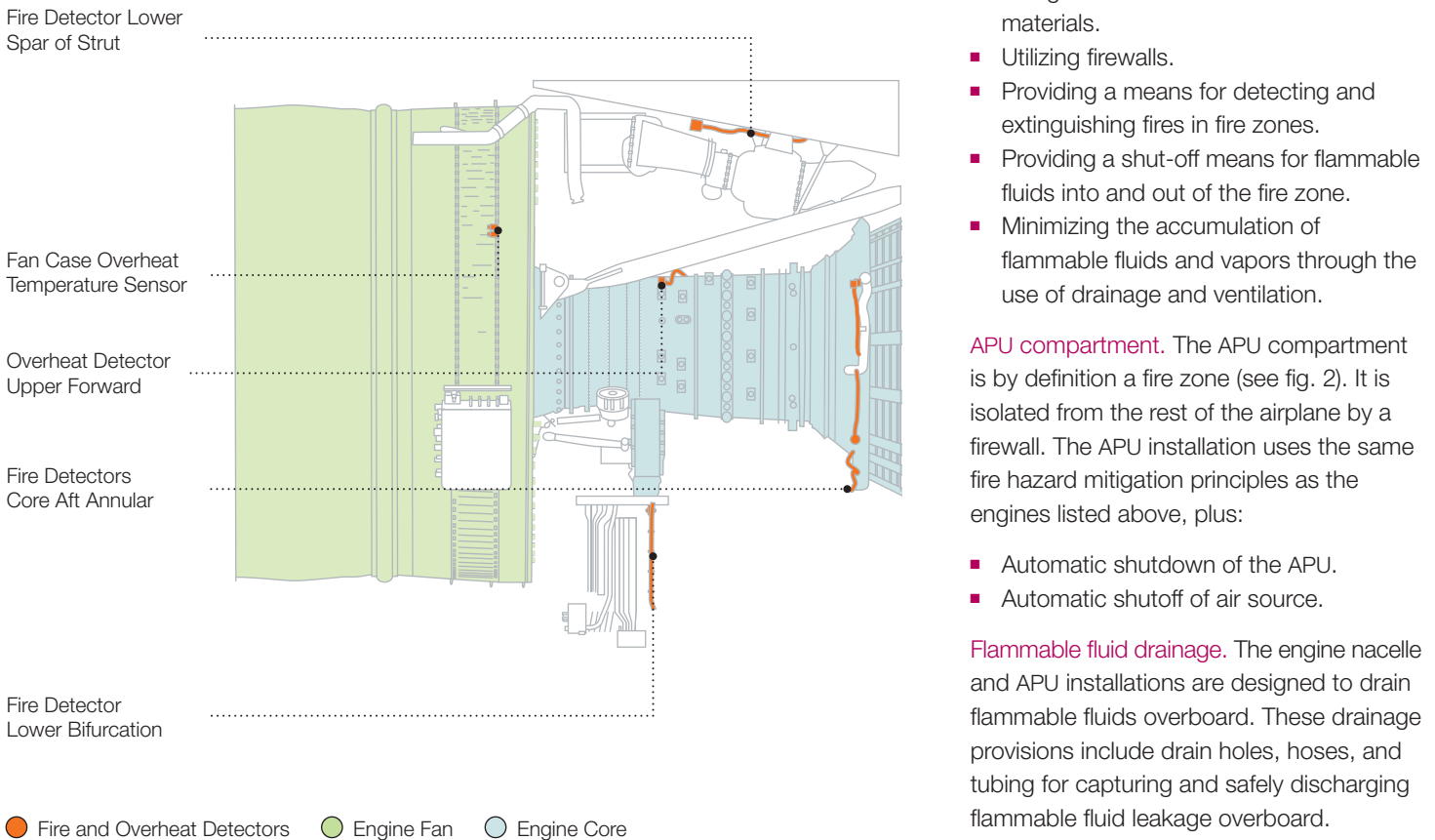

is designated as a zone, such as fire zone, flammable fluid leakage zone, or dry bay zone, according to the potential for the presence of flammable fluids and ignition sources (see fig. 1).

Only the compartments that contain ignition sources and the potential for flammable fluid leakage are classified as fire zones. Examples are the engine case around the compressor, combustor, and turbine sections of the engine. The gearbox and its accessories are also considered potential ignition sources during failure conditions that could cause temperatures to exceed the auto ignition temperatures of fluids that may be present in the compartment. The areas adjacent to the engine fire zone — such as the engine fan compartment, strut or pylon, and strut heat shield — are isolated by firewalls. Other compartments are isolated by bulkheads and vapor barriers. Boeing mitigates fire hazards in engine and nacelle compartments by:

- Minimizing the potential for ignition.
- Using compartmentation and isolation.
- Routing flammable fluid-carrying lines away from electrical wires and hot pneumatic ducts.
- Using nonflammable construction materials.
- Utilizing firewalls.
- Providing a means for detecting and extinguishing fires in fire zones.
- Providing a shut-off means for flammable fluids into and out of the fire zone.
- Minimizing the accumulation of flammable fluids and vapors through the use of drainage and ventilation.

**APU compartment.** The APU compartment is by definition a fire zone (see fig. 2). It is isolated from the rest of the airplane by a firewall. The APU installation uses the same fire hazard mitigation principles as the engines listed above, plus:

- Automatic shutdown of the APU.
- Automatic shutoff of air source.

**Flammable fluid drainage.** The engine nacelle and APU installations are designed to drain flammable fluids overboard. These drainage provisions include drain holes, hoses, and tubing for capturing and safely discharging flammable fluid leakage overboard.

## Figure 5: Engine fire-extinguishing system

On this airplane model, two fire-extinguishing-agent bottles and associated tubing are installed in the leading edge of each side of the wing.

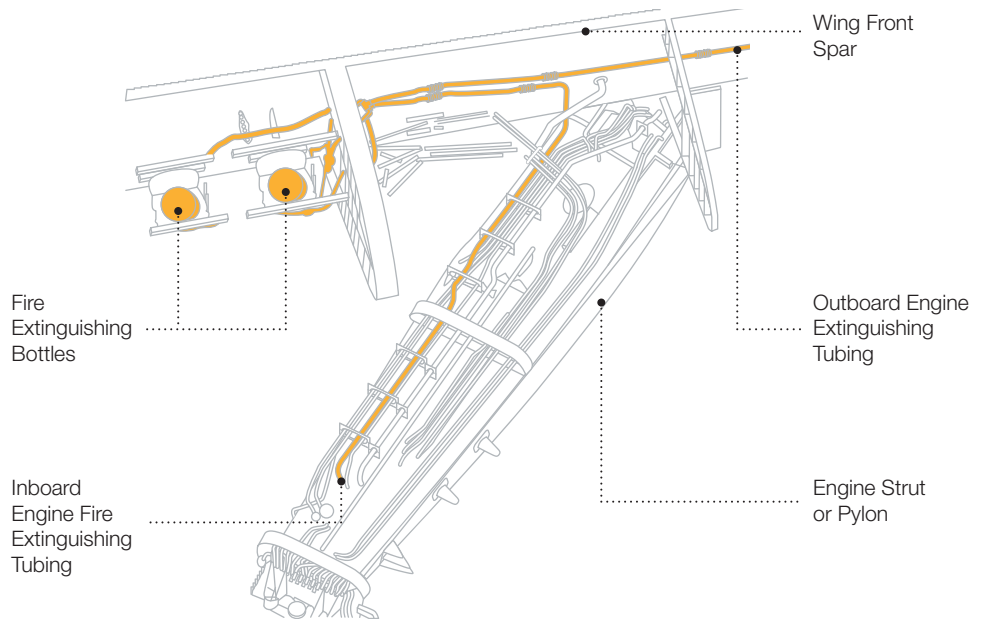

**Ventilation.** In the engine pod, ventilation air is provided in fire and flammable fluid leakage zones to minimize the accumulation of flammable vapor. All ventilation flow is designed to exit safely without being reingested. In the engine core fire zone, controlled cooling flow provides a source of core ventilation. Some installations have dedicated ventilation inlets. The APU compartments are ventilated by either a mechanically driven fan or a passive eduction cooling system. Any flammable vapors are forced out through vent openings or through the eduction exhaust system. The airflow driven by either of these two systems prevents the accumulation of flammable vapors and provides cooling for hot surfaces.

**Firewalls.** The strut and nacelle areas adjacent to the engine fire zones are isolated by a firewall extending from the engine fan frame to the exhaust nozzle (see fig. 3). For engines with fan compartment mounted gearbox and accessories, the entire fan cowl and thrust reverser inner cowling are designed to be fireproof for in-flight conditions. The upper quadrant of the fire zone compartment (typically +/- 45 degrees of the engine core compartment) will prevent burn-through to the adjoining strut and wing structures for the ground condition. In addition, fireproof feedthroughs, boots, seals, and sealants are used to seal penetrations and gaps on firewalls and barriers to prevent flammable

fluid, vapor, or the propagation of fire to adjacent zones.

Most APU installations are located in the airplane tailcone outside of the pressure vessel or passenger compartment. This provides a high level of isolation. The APU compartment is further isolated from the forward sections of the airplane by a fireproof compartment firewall. Other APU installations not located in the airplane tailcone are in self-contained compartments with firewall structure surrounding them on all exposed sides within the airplane.

**Bonding and grounding.** All Boeing airplanes incorporate electrical bonding or grounding provisions for electrical system components and structure to protect against static electricity, sparking, or the arcing that occurs between surfaces resulting from electrical system faults or lightning strikes. The bonding or grounding prevents conditions that could ignite flammable vapors.

**Explosion proofing.** Electrical components installed in the fire or flammable fluid leakage zones are required to be explosion proof. In the event that flammable fluid or vapor seeps into a cavity of the component, it is required to contain the fire should the flammable fluid ignite. The components are also required not to overheat and become an ignition source. Each component type is tested in a laboratory environment to demonstrate that it meets these requirements.

## ACTIVE FIRE-PROTECTION SYSTEMS

**Engine fire detection.** The typical engine fire-detection system includes both fire and overheat detectors (see fig. 4). Each detector location has two heat-sensing elements along with associated support tubes, brackets, and electrical connectors. Sufficient area coverage is required to ensure prompt detection of a fire within the fire zone. The detector elements of the fire- or overheat-detection system are configured to form two redundant loops, with each detector loop monitored by a separate control card or a controller. Signals from the detectors are processed through an automatic fire-and-overheat-logic-and-test system to generate flight-deck displays and aural warnings to alert the crew in the event of an engine fire. Alerts are displayed in the form of lights (i.e., a red MASTER WARNING for fire and an amber CAUTION for overheat), together with the simultaneous illumination of the associated engine-fire handle and fuel-shutoff switch for an engine fire. On airplanes with engine-indication-and-crew-alerting-system (EICAS) capability, EICAS messages are shown on the integrated flight-deck displays. An EICAS message also appears in the event of a detector system failure.

**APU fire detection.** The typical APU fire-detection system consists of two or three detectors connected in series by airplane wiring, each with a redundant detector



## Figure 6: Fire-extinguishing control

Controls for all airplane fire-extinguishing systems are located on the flight deck. This control module for the 747 shows controls for all four engines, the APU, and the cargo hold. The respective fire handle illuminates red if an engine fire condition is detected. Pulling the fire handle arms the fire-extinguishing system and shuts down the engine. It also shuts down the fuel furnished to that engine, the pneumatic system, the hydraulic system, and the electrical system associated with that engine. Rotating the fire handle discharges extinguishing agent into the engine.

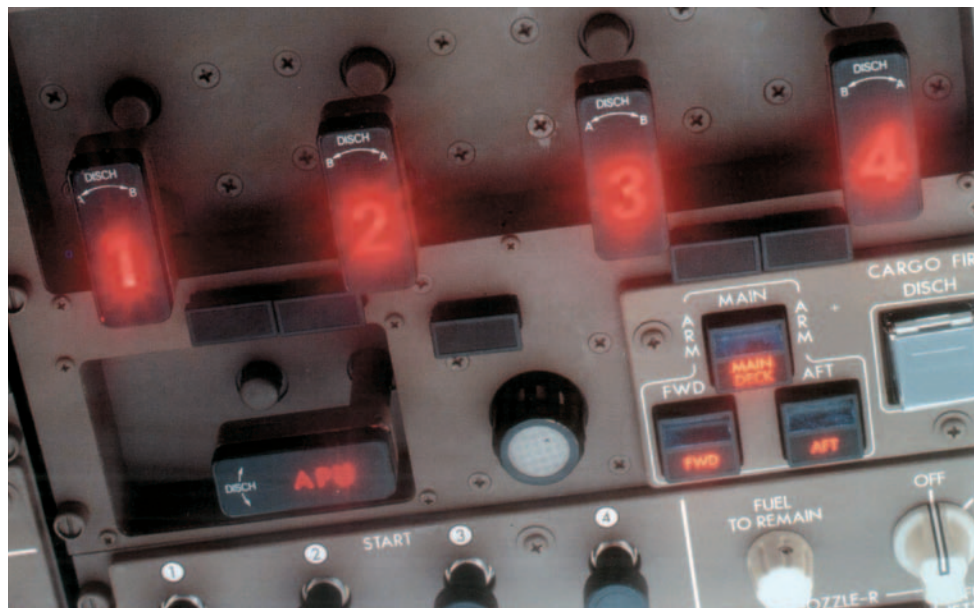

element (referred to as a detector loop) with both ends connected to the control card. The APU detection system uses the same type of detector elements, circuitry, operation, testing methods, and certification procedures as the engine fire-detection system. The fire detection system will automatically shut down the APU when a fire is detected. The fire detector assemblies are contained entirely within the APU compartment in locations selected to provide maximum coverage of the compartment where fire could occur and to ensure prompt fire detection.

APU fire-detection displays and controls are located on the flight deck. When a fire is detected, the APU fire handle illuminates, the MASTER WARNING lights illuminate, warning and status messages are displayed on EICAS, and the aural warning is activated. An external APU fire horn that is resettable from the flight deck (or from the APU fire/shutdown panel near the wheel well or away from the APU) is also provided.

**Engine fire extinguishing.** Engine fire-extinguishing systems consist of extinguishing-agent high-pressure bottles, distribution tubing, nozzles, and flight-deck controls and displays. Two fire-extinguishing-agent bottles containing Halon 1301 and interconnecting tubing are installed in a location where they can serve two engines, although there are airplane models that have two independent bottles serving each engine.

On some airplane models, the bottles are installed in the left and right wing leading edge (see fig. 5). On other models, they are mounted in the fuselage or in the strut or pylon. Each engine fire zone is required to be protected by two independent extinguishing-agent bottles, each capable of extinguishing a fire within the zone.

**APU fire extinguishing.** The APU fire-extinguishing system located in the aft fuselage is a single-shot system provided to extinguish a fire in the APU compartment. The system consists of the extinguishing-agent bottle, distribution tubing, discharge nozzle, and necessary flight-deck controls and displays. The fire-extinguishing-agent bottle is located on the forward side of the APU firewall. The single discharge line directs agent to a nozzle located in the APU compartment.

The APU-extinguishing-agent bottle design is similar to that of the engine. However, the APU bottle has a single discharge outlet rather than two, and the service pressure, amount of agent, and safety relief valve opening pressures differ. Some APU installations have options for a second APU bottle, for automatic fire extinguisher discharge, and for the use of an engine bottle in place of the standard APU bottle. The fire-extinguishing systems for both the engines and APU are controlled from the flight deck (see fig. 6).

## TESTING OF FIRE PROTECTION SYSTEMS AND COMPONENTS

Boeing conducts airplane ground and flight testing of various aspects of the engine and APU fire-protection systems. Testing includes:

- Fire detection system.
- Fire-extinguishing-agent concentration.
- Fluid drainage, both on ground and in-flight.
- Temperature margin verification for fire detectors.
- Laboratory qualification of all system components.
- Laboratory fire tests for firewalls, feedthroughs, fire seals, installation components, and flammable fluid carrying components, in simulated installed conditions.

## SUMMARY

Boeing places the highest importance on designing and certifying fire protection systems on an airplane. The engines and APUs incorporate extensive fire protection, including detection and extinguishing systems.

For more information, please contact Sham Hariram at [sham.s.hariram@boeing.com](mailto:sham.s.hariram@boeing.com). 



Operational acceptance, which is required for any custom ASO LSAP, is performed by the airline's regulatory authority and can vary for each agency.

# Updating 787 Airplane Software Configurations

Airlines now have the capability to change a number of software options on the 787 without requiring a service bulletin from Boeing. Setting of these options, which are referred to as airline selectable options (ASOs), is enabled by the Airline Selectable Options Tool (ASOT). This article discusses ASOs, the use and benefits of ASOT, and the associated Boeing guidelines.

**By Ronald Trees**, Airline Selectable Options Tool Project Manager, and  
**Susan Tankersley**, 787 e-Enabling Implementation and Deployment Project Manager

When an airline orders a Boeing airplane, it specifies settings for the configurable software options for that airplane. These options configure the operation of the airplane when loaded to their respective line replaceable units. Because these options are delivered as part of the airplane type certification, changes to an airplane's software configuration requires a service bulletin from Boeing.

Starting with the 787 Dreamliner, Boeing worked with the U.S. Federal Aviation Administration (FAA) to make it possible for airlines to change a number of airplane software options without requiring a service bulletin. This enables airline cost

reductions, condenses airplane reconfiguration flow time, and streamlines processes. Airlines can configure these options using the Web-based ASOT accessed through the Web portal MyBoeingFleet.com. The ASO-capable systems are shown in figure 1. All possible ASO settings for these systems are certified during 787 type certification, so a Boeing service bulletin is not required to reconfigure these software options.

Airlines are responsible for obtaining regulatory operational acceptance of the resulting custom ASO loadable software airplane parts (LSAP) for the 787 ASO-capable systems.

## BENEFITS OF ASOs

A number of benefits result from ASOs, including:

- Greatly decreased time for an airline to create a new airplane configuration. Boeing estimates that the use of ASOs will cut as much as 11 weeks from the process, compared to the previous method.
- Reduced FAA Part 25 regulatory authority workload. There is no recurring Part 25 involvement with customer configuration of ASOs.
- Decreased workload and cost to reconfigure airplanes.



## Figure 1: 787 systems with airline selectable options

Airlines can use the ASOT to configure 68 options in these loadable software airplane systems.

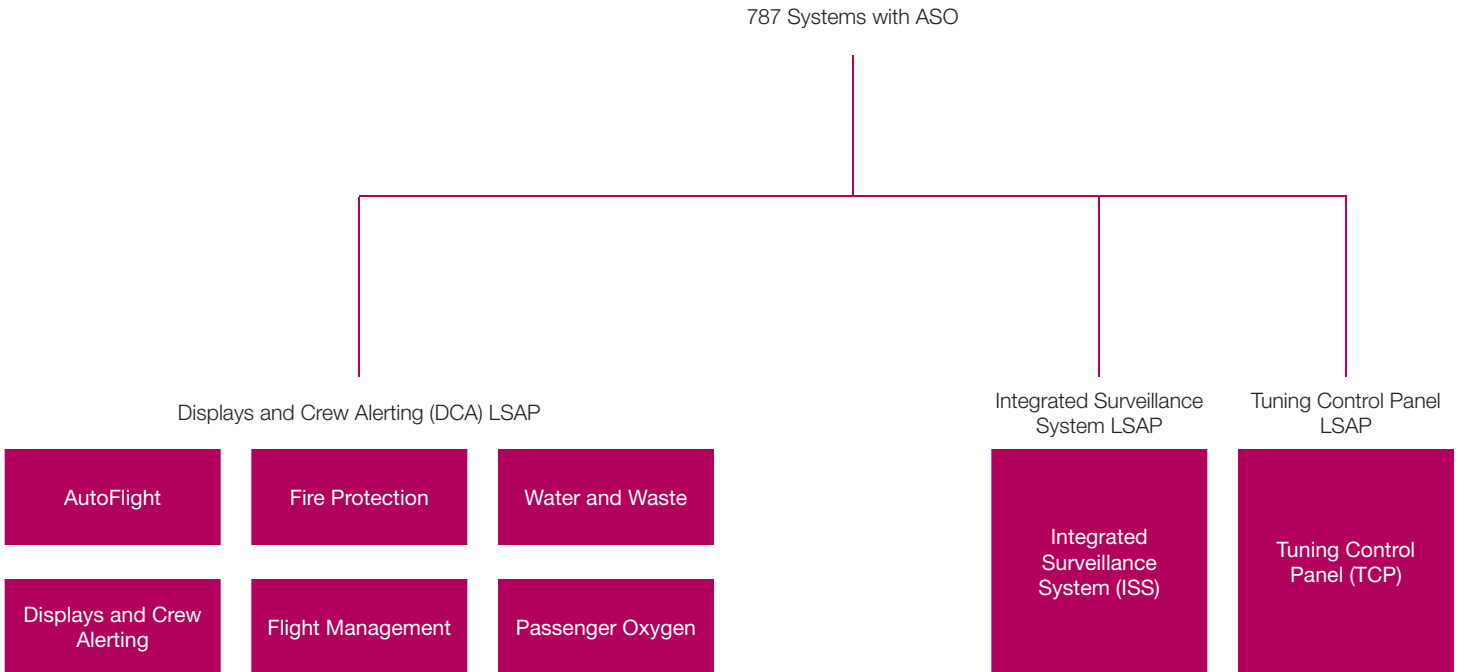

### USING THE ASOT

Boeing maintains the ASOT throughout the life of the airplane and provides ASO services to airlines that do not want to generate custom ASO LSAPs.

The ASOT allows the airlines to:

- Access ASO documentation, including:
  - Airline Process Guidance Document, D6-83640.
  - ASO Description Document, D610Z010-01.
  - ASOT User Manual, D6-83469-700-1.
- Modify ASO selections.
- Generate and manage ASO LSAP.
- Generate reports.

- Request flight crew operating manual (FCOM) updates associated with the options changes.

The ASOT runs on a Web browser on a standard personal computer and can be accessed via MyBoeingFleet.com (see fig. 2). Adobe® Reader is required to display PDF files. The ASOT fully validates user inputs and verifies the LSAP against the user inputs as a qualified verification tool per RTCA/DO-178B, Software Considerations in Airborne Systems and Equipment Certification (the FAA process requirements for in-flight software certification).

The ASOT uses definition files and assignment files to create ASO LSAPs. Definition files, which are provided and

managed by Boeing, define the available options and their attributes, including allowed values and value constraints. An assignment file, created by the airline, allows the airline to select values for each available option (see fig. 3).

The selected options values are used to generate an ASO LSAP (see fig. 4).

The ASOT also incorporates full reporting capabilities, enabling the airline to generate reports (see fig. 5). The reports include detailed information such as:

- LSAP configuration.
- Configuration of files used to generate the LSAP.
- Settings of the airline options.

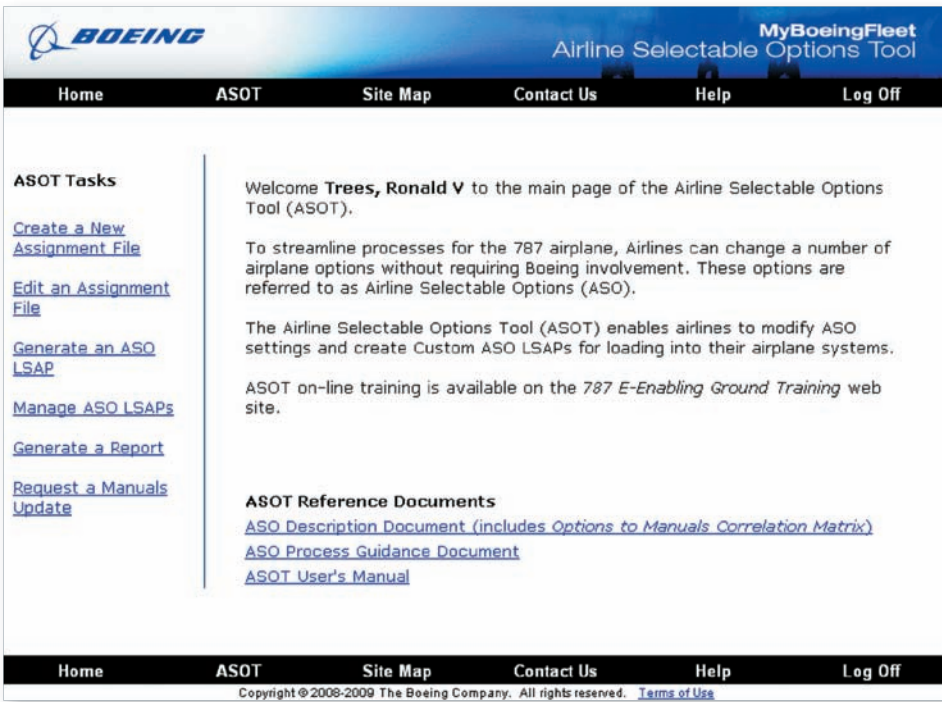

**Figure 2: ASOT Welcome page**

The ASOT Welcome page, which is accessed from the My Products section of the MyBoeingFleet home page, provides access to all the tool functions and documentation.

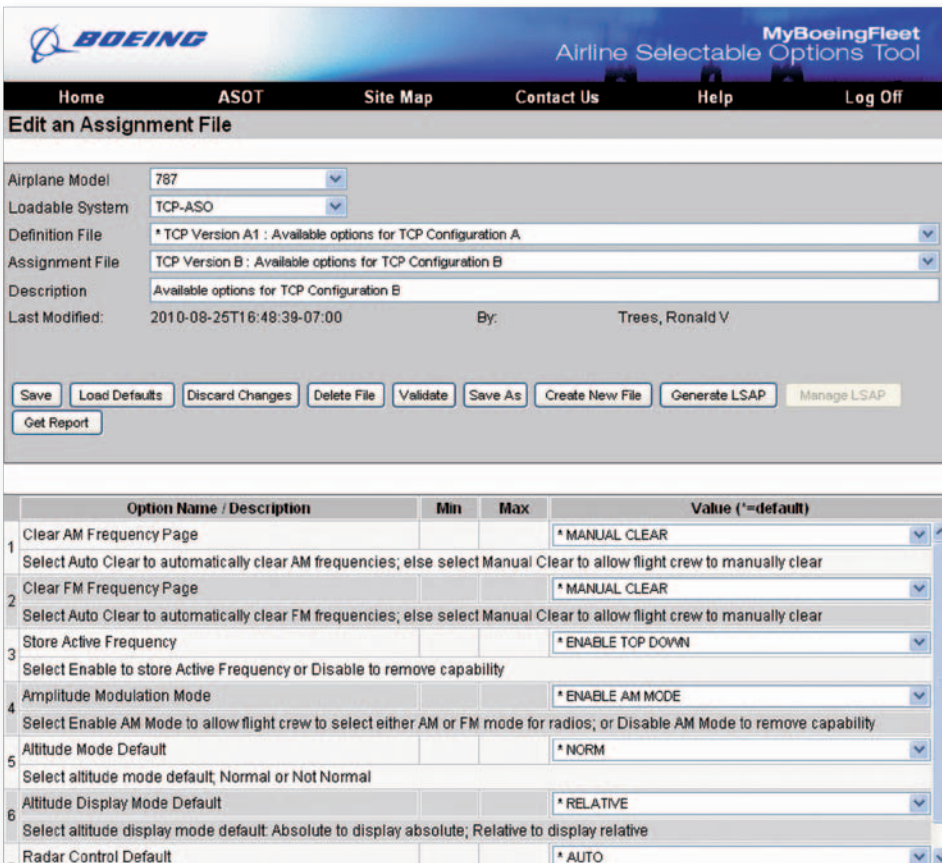

**Figure 3: Editing an assignment file**

The airline uses this simple form to select option values.

## Figure 4: Generating an ASO LSAP

The user can provide additional description information when an ASO LSAP is generated.

The screenshot shows the 'Generate an ASO LSAP' interface. At the top, there is a navigation bar with 'Home', 'ASOT', 'Site Map', 'Contact Us', 'Help', and 'Log Off'. Below this, the main form contains the following fields:

- Airplane Model:** 787
- Loadable System:** TCP-ASO
- Definition File:** \* TCP Version A1 : Available options for TCP Configuration A
- Assignment File:** TCP Version B : Available options for TCP Configuration B
- Part Number:** BCG CC-ABCB - LSAP MMMCC-SSSS-SSSS
- Description:** TCP ASO LSAP for Configuration B
- Sensitivity Level:** Company ABC Proprietary
- ECCN:** (empty field)

At the bottom of the form, there are two buttons: 'Generate LSAP' and 'Manage LSAP'.

## Figure 5: LSAP report

The first section of the LSAP report shows the configuration information for the LSAP.

Subsequent sections of the LSAP report show the airline option selections for the LSAP.

**Company ABC Proprietary  
LSAP Report  
Part Number: BCG4A-ABCB-LSAP**

Airplane Model: 787

---

**Configuration**

Report Configuration Management Information:

Report Date:	2010-08-28 15:37:09+00:00
Report Created By:	Trees, Ronald V
Airline Code:	JAR
ASOT Version:	07.00.00

ASO LSAP Configuration Management Information:

Part Number:	BCG4A-ABCB-LSAP
ASO LSAP Description:	TCP ASO LSAP for Configuration B
Sensitivity Level:	Company ABC Proprietary
ECCN:	
Generated Date:	2010-08-28 15:36:47+00:00
Generated By:	Trees, Ronald V
Verification Passed?	yes
Constraint Errors?	no

First section

**Company ABC Proprietary  
LSAP Report  
Part Number: BCG4A-ABCB-LSAP**

Airplane Model: 787 Loadable System: TCP-ASO

Option Values - Option Data File: Options File	Selected Value	Description
1 Clear AM Frequency Page	MANUAL CLEAR	Select Auto Clear to automatically clear AM. Manual Clear to allow flight crew to manually
2 Clear FM Frequency Page	MANUAL CLEAR	Select Auto Clear to automatically clear FM. Manual Clear to allow flight crew to manually
3 Store Active Frequency	ENABLE TOP DOWN	Select Enable to store Active Frequency or T
4 Amplitude Modulation Mode	ENABLE AM MODE	Select Enable AM Mode to allow flight crew mode for radios, or Disable AM Mode to rem
5 Altitude Mode Default	NORM	Select altitude mode default: Normal or Not
6 Altitude Display Mode Default	RELATIVE	Select altitude display mode default: Absolute Relative to display relative
7 Radar Control Default	AUTO	Select radar control default: Auto or Manual

Subsequent sections

### ONLINE TRAINING AVAILABLE THROUGH MYBOEINGFLEET

Training for the ASOT is hosted on MyBoeingFleet at the 787 e-Enabling Ground Training Web site. To access the training, the user needs to have a MyBoeingFleet account and the account must have been granted access to 787 e-Enabling Ground Training.

### ASO PROCESS FOR IN-PRODUCTION AIRPLANES

The airline's role while the airplane is in production is limited to providing the option

selections based on its desired airplane operations. Boeing will use the airline-provided selections to create the customized ASO LSAP that is included with the delivered airplane. Boeing has created an ASO description document and worksheets to help airlines determine option selections. The ASO description document provides details about the options, including pictorial examples of airplane display options and symbols, and their available settings.

### ASO PROCESS FOR IN-SERVICE AIRPLANES

A modification to an in-service airplane requires the airline to create a new ASO LSAP (see fig. 6) for one of two reasons:

- **A change to an option has occurred in one of the ASO-capable systems.** In this case, Boeing notifies the airline via a service bulletin that a new version of operational software is available and a new ASO LSAP needs to be created and loaded with the new version of operational software.



## Figure 6: ASO processes for in-service airplanes

This is the general process flow when creating new ASO LSAPs for in-service airplanes. The detailed process is specified in the ASO Process Guidance Document.

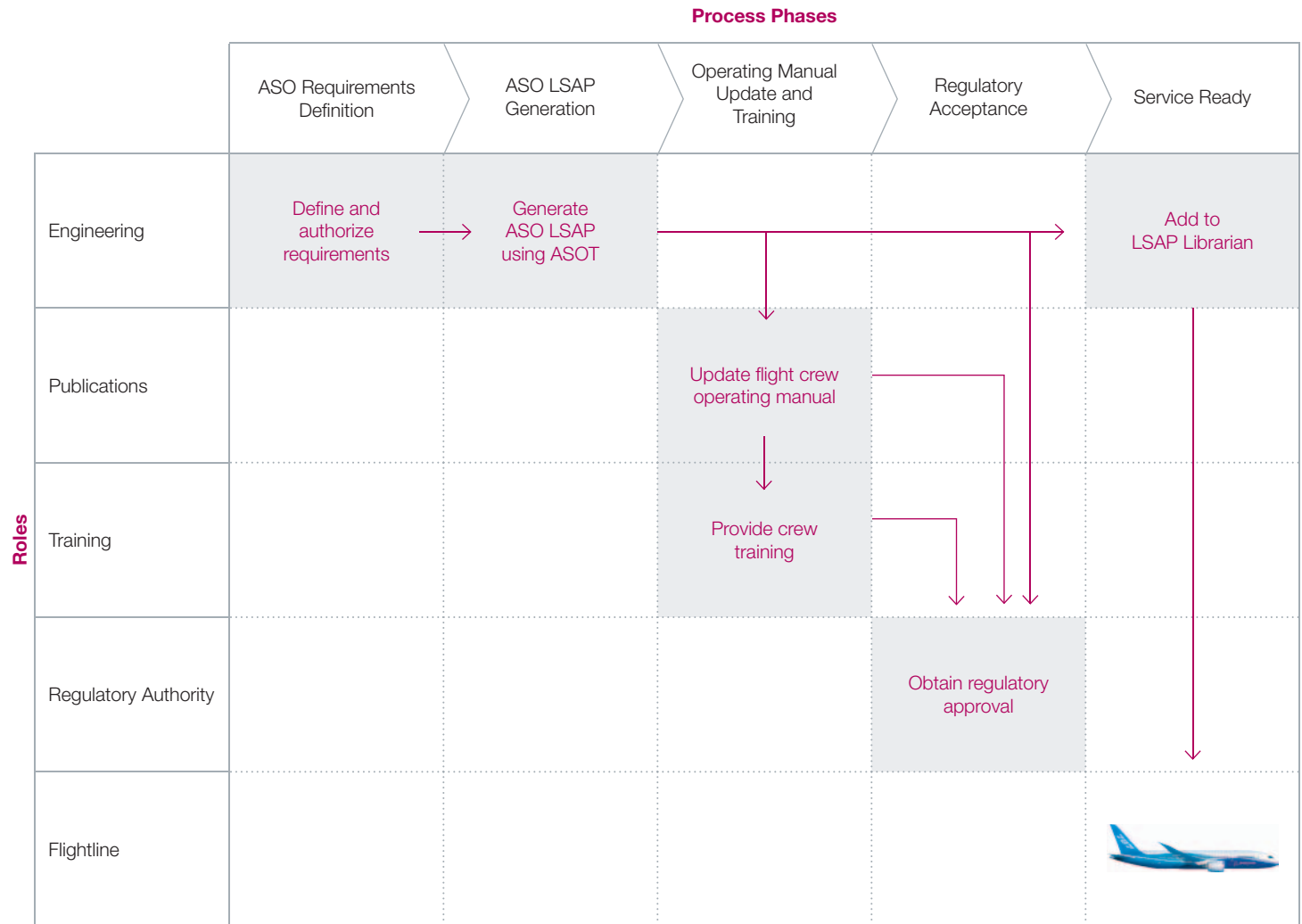

- The airline wants to change the configuration of the ASO-capable systems. In this case, the airline can create a new ASO LSAP on its own initiative.

Before performing any work with the ASOT, the airline needs to define the ASO requirements depending on the desired operation of the airplane. Once the requirements are defined, the new ASO LSAP can be generated using the ASOT. Because the option selections can cause changes in the FCOM, the airline must notify Boeing of the changes so the manual can be generated. The ASOT provides a link to Boeing that automates this function. A new custom ASO LSAP may also require the airline to perform crew training.

Operational acceptance, which is required for any custom ASO LSAP, is performed by the airline's regulatory authority and can vary for each agency.

Boeing worked with the FAA to obtain agreement on the ASO process. This agreement is documented in an Item of Record (IOR), "Airline Selectable Options (ASO) and ASO Tool (ASOT), FAA IOR number SA-2," and is included in the ASO airline process guidance document, which is available from Boeing and is accessible on the ASOT Welcome page (see fig. 2). Airlines may use this IOR to work with their regulatory authorities as needed.

### SUMMARY

The new ASOT allows airlines to configure and manage a number of selectable software options on the 787. Airlines will be able to update specific software options, generate and manage LSAPs, and request FCOM updates without Boeing service bulletins.

For more information, please contact Susan Tankersley at [susan.d.tankersley@boeing.com](mailto:susan.d.tankersley@boeing.com). 

# New Service Request Draft

Subn

Draft Name: 1-P61108

## Contact Information

Your Name

TBC

Field Base: BFSMEL-QAN-Melbourne-Australia

## CC'd Contacts:

Add/Remove Contacts

No Records

Last Name	First Name	Account

## Product Information

Product Type: \*

Airplane

Product Line: \*

737

Product: \*

737-900

ATA: \* 5410-00

Add/Remove Part Information

Part #:

Part Serial #:

## Airplanes

Add/Remove Airplane

Serial #	Regis

Subject: \* New service request being created

## Attachments

Add File

File	File Type	File Size	Remove
<u>Damage Pic</u>	jpg	755 kb	

Upload Complete

## References

Add Re

Ref #	Title
/A/	TBC-TBC-10-0001



02-Sep-2010 11:59:59 PM



Metal Repair

General Description \*

The Service Requests Application provides customers with better tracking and streamlined communication with Boeing technical experts.





# New Service Requests Application

To improve support to customers, Boeing is providing a single standard input method for submitting requests for in-service support. This new application, hosted on the Web portal MyBoeingFleet.com, replaces other methods of submitting service requests, such as e-mail, fax, and Technical In-Service Requests (i.e., TISRs).

By **Sevket Numanoglu**, Program Manager

Boeing has a long history of providing its customers with technical support to ensure the safe and efficient operation of the Boeing in-service fleet. Continuing with that commitment, Boeing is enhancing its method of processing requests for in-service technical support.

This article describes the new Service Requests Application and how it provides Boeing customers with more responsive service.

## IMPROVING THE SERVICE REQUEST PROCESS

Historically, Boeing has accepted service requests through a variety of means,

including corporate or personal e-mail and fax. In 2009, to ensure prompt processing and completion of requests for airplane technical support, Boeing began transitioning all requests for technical services to the Service Requests Application hosted on the Web portal MyBoeingFleet.com (see fig. 1).

The application is an electronic form that enables customers to fill in all the relevant information for a service request and send it to an electronic repository for faster, more complete submission, and enables traceable action by Boeing (see fig. 2). It replaces the need to send multiple faxes and e-mails to Boeing individuals and groups or to use TISRs.

Exceptions to this process include certain maintenance forms and catalog

orders. The Customer Originated Change, Service Bulletin Incorporation, or Publication Change Request forms will remain available from the Maintenance Documents link on MyBoeingFleet. All Data and Services Catalog orders may continue to be made from the Data and Services Catalog link on the MyBoeingFleet home page.

The Service Requests Application provides the ability to input all the information required to create a complete service request and route it to the appropriate expert. This results in a faster and more thorough response to customer requests, making this the preferred method to request in-service support. In addition, the application provides customers with the ability to monitor all open requests and



## Figure 1: The new Service Requests Application on MyBoeingFleet

The new Service Requests Application enables Boeing to provide faster, more accurate responses to requests for service, making it the preferred way to submit a service request directly to Boeing.

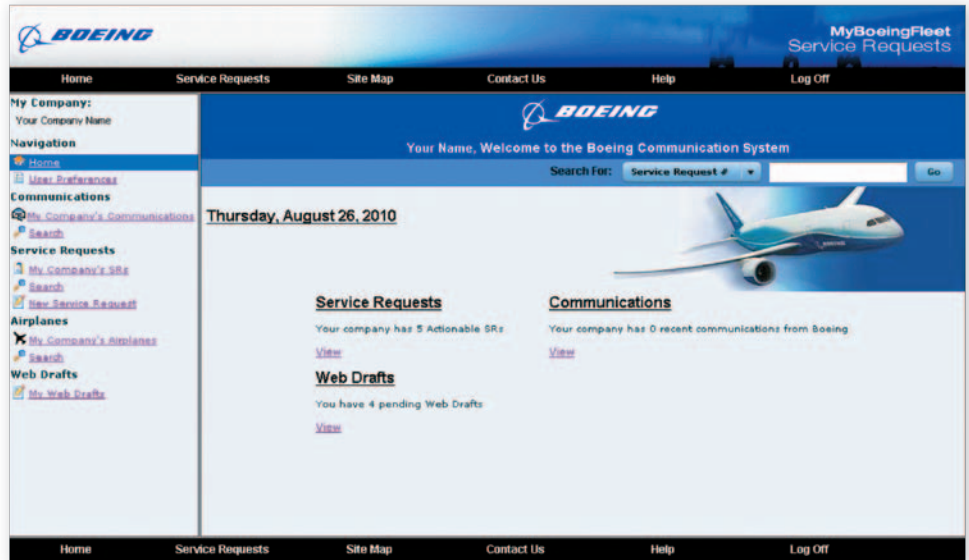

## Figure 2: Online form streamlines service requests

The Service Requests Application provides an electronic form that enables customers to fill in relevant information for service requests. Files can be attached and sent with the request for service.

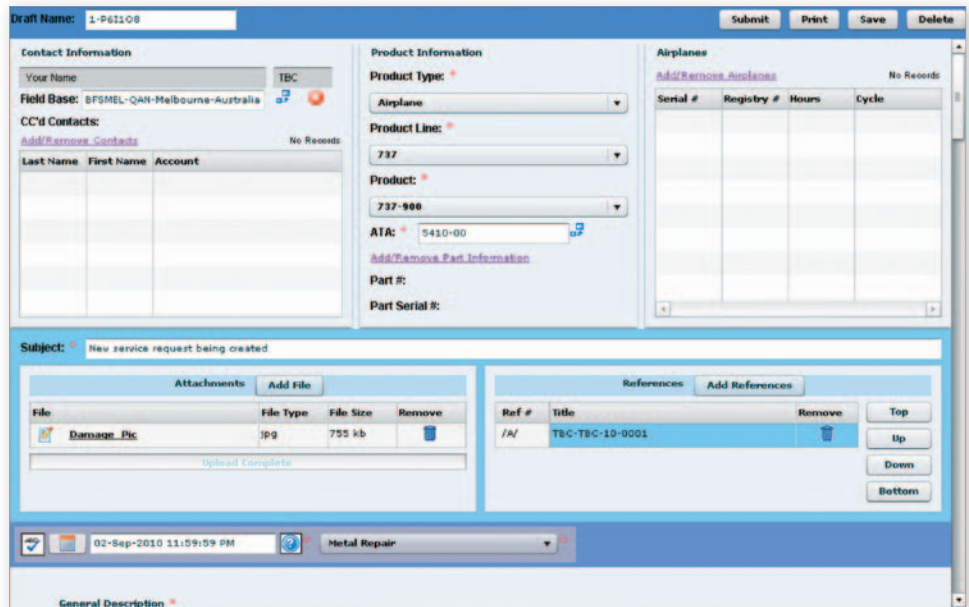

review historical requests. The improved data quality resulting from using the application can help Boeing engineers spot trends more easily and be more proactive in dealing with issues.

There is no additional charge for the Service Requests Application if an operator is already using MyBoeingFleet.com. Support is available to help customers activate the application by contacting Boeing Digital Data Customer Support at [ddcs@boeing.com](mailto:ddcs@boeing.com).

### BENEFITS TO CUSTOMERS

The Service Requests Application allows customers to have accurate and real-time

status of service requests. As a result, customers should experience better tracking and streamlined communication with Boeing technical experts. Other benefits for customers include:

- Queries and searches for more accurate information management.
- Enhanced information security.
- Single point of entry, and improved visibility of service requests throughout each customer's organization.
- Customer control of read-only and read-write access rights.
- Templates that enable customers to submit only the essential information for the specific request.

### SUMMARY

The new Boeing Service Requests Application, available on MyBoeingFleet, is designed to improve support to operators. Further details on accessing the Service Requests Application are available at <http://www.boeing.com/commercial/aviationservices/brochures/ServiceRequestsApplication.pdf>.

For more information, please contact Boeing's Digital Data Customer Support at [ddcs@boeing.com](mailto:ddcs@boeing.com). **A**



